



Defender™ 5000

Rectangular Scales



Smart Functionality, Durability, Ohaus Quality and Value

The Ohaus Defender™ 5000 Series is a feature-rich line of bench scales, combining an ABS plastic T51P indicator with rectangular painted steel bases and columns. Ideal for shipping and receiving, production, packaging and general commercial and industrial weighing applications, the Defender 5000 offers a multifunctional indicator with multiple weighing units and software modes to meet the requirements of industrial and lab applications. With rugged construction, comprehensive yet intuitive software and multiple connectivity options, the Defender 5000 can meet the needs of demanding industrial operations.

Standard Features Include:

- Painted steel base with ABS indicator
- 5,000-7,500d default resolution
- Quick display of results using large LCD with high-contrast white backlight
- Temporary display of 10x readability in weighing mode using quick key press
- Easy to operate with 4-key membrane keypad with raised tactile keys
- Weighs in one or more units: kg, g, lb, oz, lb:oz (decimal), tonnes and user-definable custom unit.
- Multiple weighing modes including Counting, Percent Weighing, Dynamic/Animal Weighing, Checkweighing, and Display Hold.
- Internal power supply with universal line cord or 6 "C" batteries (80 hour battery life) – optional NiMH internal rechargeable power pack available
- Includes RS232 interface with GMP/GLP data output including date and time
- Base and indicator connected using quick connect plug
- Optional interfaces include DC relay control kit, AC relay control kit, 2nd RS232 and RS485/422

Defender™ 5000 Rectangular Scales

The Defender 5000 Offers Multiple Features and Easy Configuration:

To meet different operational needs, the Defender 5000 includes a suite of configurable software:

- Counting mode for packaging and inventory control, enabling counting into a container or out of a container for bulk operations. Supports a maximum counting resolution to 1:300,000 (minimum APW equal to 0.1d), selectable auto-optimization of average piece weight (APW). APW data can be displayed at any time using a quick key press.
- Percent Weighing mode for formulation and mixing applications, with display of reference weight with quick key press.
- Dynamic/Animal Weighing with selectable weigh times from 0-60 seconds.
- Checkweighing function for packaging and weight checking, with display of results using LCD display and red/yellow/green LEDs. Audible beeper can be configured to prompt when weight is within range, under, over, or under or over range. Target weight values can be displayed at any time using a quick key press.
- Display Hold mode for weighing large packages holds last stable weight on display until cleared
- The Defender 5000 weighs in one or more user-selectable units: kg, g, lb, oz, lb:oz (decimal), tonnes and user-definable custom unit
- Supports GMP/GLP data output with date, time user ID, project ID and scale ID. The Defender 5000 features selectable print options for data and print format
- To limit operator access to functions, the Defender 5000 offers both software lockouts for menu items as well as individual key functions.

Outline Dimensions

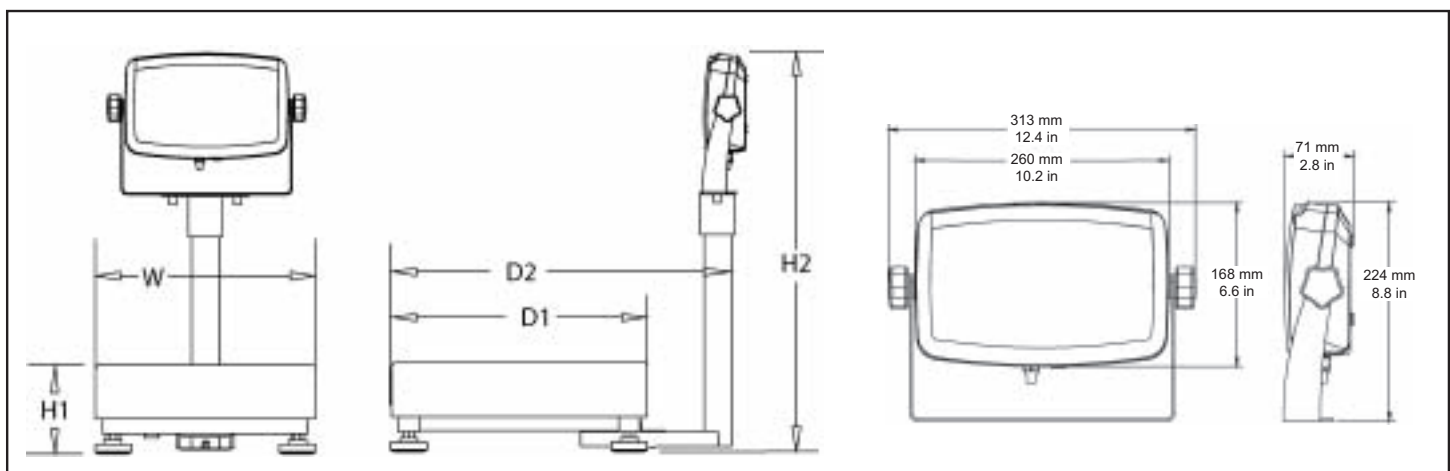

Standard Features:

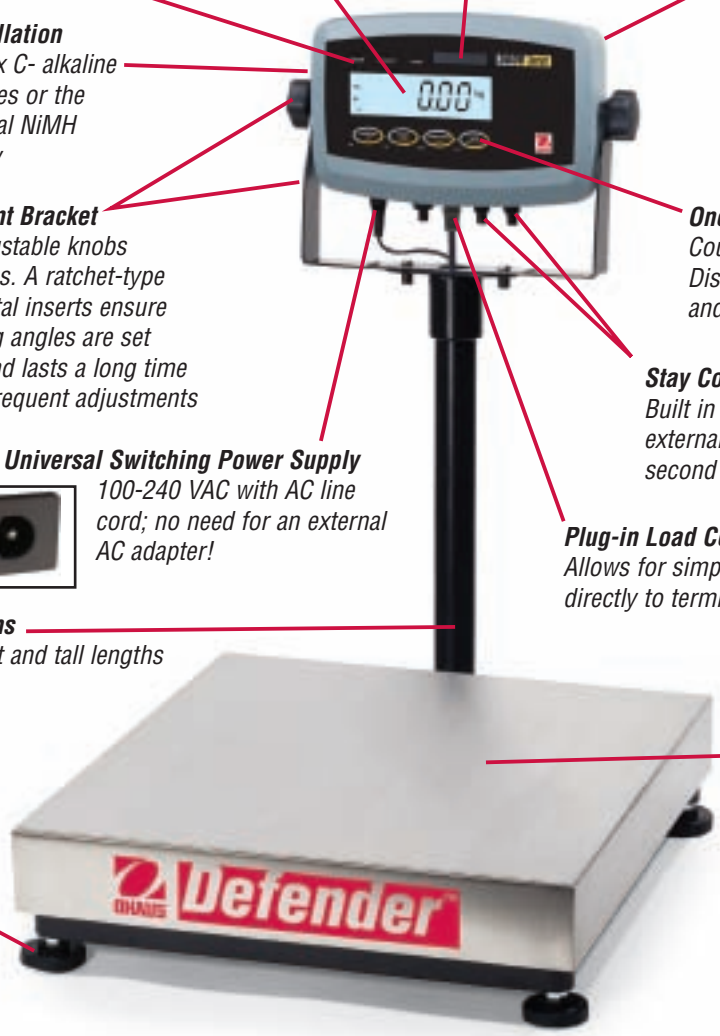

High-Visibility LCD Display
with bright white LED back-light. Fast display stable weight within 2 seconds

Internal Slot for Capacity Label
Protects label from the effects of moisture and external environments

Reversible Rear Housing
Cables can exit above (table or front scale mounting) or below (wall or bench scale mounting) for convenient mounting. Front scale mounting with available accessory. Internal structural ribs provide strength and minimize flexing.

3-Color LED Checkweigh Indication
with configurable beeper alert

Simple Plug-In Battery Installation
Use six C- alkaline batteries or the optional NiMH battery

Included Table/Wall Mount Bracket
With large ergonomic adjustable knobs to maximize viewing angles. A ratchet-type angle adjustment with metal inserts ensure that viewing angles are set securely, and lasts a long time even with frequent adjustments

Universal Switching Power Supply
100-240 VAC with AC line cord; no need for an external AC adapter!

Painted Steel Columns
Available in both short and tall lengths

One-Key, Multiple Mode Selection
Counting, Dynamic Weighing, Display Hold, Percent Weighing and Checkweighing

Stay Connected
Built in RS232 bi-directional interface and built-in external input, optional RS422/485, optional second RS232 and optional AC or DC relay

Plug-in Load Cell Connector
Allows for simple connection to Defender bases or directly to terminal block.

Durable Base Frame Construction
Stainless steel pans and painted steel form-and-weld painted steel frames (R, L bases) provide maximum durability, rigidity and structural integrity. Load-unload cycle tested to ensure long-term performance.

Fully Adjustable Feet
Four rugged, adjustable feet help prevent slippage on wet or uneven surfaces

Options and Accessories

Interface Options

	OHAUS Number
AC Relay Kit.....	80500720
DC Relay Kit.....	80500727
RS485/422 Interface Kit	80500731
Second RS232 Interface Kit.....	80500733
Foot Switch	71173378

Power Options

Rechargeable Battery Kit, T51P/T51XW.....	80500729
---	----------

Other Accessories

RS232 Cable to SF42 Printer	80500571
RS232 Cable to PC 25-pin.....	80500524
RS232 Cable to PC 9-pin	80500525
Compact Impact Printer, 42 Column	SF42
Paper for SF42 printer (5 pack).....	12101511
Ribbon for SF42 printer.....	12101512

Defender™ 5000 Rectangular Scales

Specifications

Model	D51P15HR1	D51P30HR1	D51P60HR1	D51P60HL2	D51P100HL2	D51P150HX2	D51P300HX2
Capacity (max) x Default Readability (d)	30lb x 0.005lb 480oz x 0.1oz 30lb : 0.1oz 15kg x 0.002kg 15000g x 2g	60lb x 0.01lb 960oz x 0.2oz 60lb x 0.2oz 30kg x 0.005kg 30000g x 5g	150lb x 0.02lb 2400oz x 0.5oz 160lb : 0.5oz 60kg x 0.01kg 60000g x 10g		250lb x 0.05lb 4000oz x 1oz 250lb : 1oz 100kg x 0.02kg 100000g x 20g	300lb x 0.05lb 4800oz x 1oz 300lb : 1oz 150kg x 0.02kg 150000g x 20g	600lb x 0.1lb 9600oz x 2oz 300kg x 0.05kg 300000g x 50g
Maximum Displayed Resolution	1:7500	1:6000	1:7500		1:5000	1:7500	1:6000
Indicator Model	T51P						
Column	13.8 in / 350 mm painted steel			26.8 in / 680 mm painted steel			
Construction	ABS plastic indicator, stainless steel removable weighing platform, painted steel column and base construction, aluminum loadcell						
Safe Overload Capacity	150% of maximum capacity						
Protection	Dry use for scale, IP67 for loadcell						
Weighing Units	lb, oz, lb:oz, kg, g, custom unit						
Modes	Static Weighing, Dynamic Weighing, Counting, Checkweighing, Percent Weighing, Display Hold						
Display	1 in / 25mm high 6-digit, 7-segment bright white backlit LCD						
Keyboard	4-button membrane switch						
Stabilization Time	Within 2 seconds						
Auto-zero Tracking	Off, 0.5, 1 or 3 d						
Zeroing Range	2% or 100% of capacity						
Calibration	Span: 1kg or 1lb to 100% of capacity / 3-point linearity (0 - 50% - 100% fixed)						
Power	100-240 VAC / 50-60Hz internal universal power supply, 6 'C' cell batteries (not supplied) with 80 hour life						
Interface	RS232 and external input						
Operating Temperature Range	14°F to 104°F / -10°C to 40°C						
Scale Dimensions (W x H1 x H2 x D1 x D2)	12 x 3.7 x 23.6 x 14 x 18.7 in 305 x 95 x 600 x 355 x 475 mm			15.7 x 4.1 x 37 x 19.7 x 24.4 in 400 x 105 x 940 x 500 x 620 mm		16.5 x 4.9 x 37 x 21.7 x 26.4 in 420 x 125 x 940 x 550 x 670 mm	
Shipping Dimensions (L x W x H)	19.3 x 16.1 x 17.3 in 490 x 410 x 440 mm			29.1 x 27.2 x 9.1 in 740 x 690 x 230 mm		29.5 x 30 x 9.1 in 750 x 710 x 230 mm	
Approx. Net Weight	25.3 lb / 11.5 kg			49.1 lb / 22.3 kg		61.1 lb / 27.7 kg	
Approx. Shipping Weight	30.2 lb / 13.7 kg			56.4 lb / 25.6 kg		67.7 lb / 30.7 kg	

Features

T51P: ABS plastic housing with internal rib reinforcements, reversible rear cover, backlit LCD weight display, checkweighing indication (green, yellow, red), membrane keypad with raised tactile keys, built-in bi-directional RS232 with manual/continuous/interval printing, external tare input, hardware configuration lockout switch, internal switching power supply with line cord and battery power using 6 "C" cell batteries.

Other Features

Zero point calibration, calibration test, span or linear calibration, selectable auto-zero tracking range, selectable stability range, selectable averaging level, selectable LCD backlight, selectable auto shutoff, retain zero weight data after power-off, Geo geographical adjustment, selectable key beep, key function lock, menu lock, selectable power-on and calibration unit, battery status display, display of gross/net weight, indication of stability, center of zero, over- and underweight, overload and underload conditions. Configuration menus for PRINT1, PRINT2, COM1, COM2, and I/O.

Compliance

- **Safety and EMC:** cUL_{US} 2005/95/EC low voltage directive: EN60950-1:2001, FCC Part 15 Class A 2004/108/EC EMC directive: EN61326-1:1997; +A1:1998; +A2:2001; + A3>2003
- **Other:** Compliant to Directive 2002/96/EC on waste electrical and electronic equipment (WEEE)
- **Quality:** Ohaus quality management system registered to ISO 9001:2000

Ohaus Corporation

* 19A Chapin Road
P.O. Box 2033
Pine Brook, NJ 07058 USA

Tel: 800.672.7722
973.377.9000
Fax: 973.593.0359

www.ohaus.com

With offices throughout Europe,
Asia, and Latin America

* **ISO 9001**
Registered Quality Management System

80774410 © Copyright Ohaus Corporation

